



Asset-Trade

Assessment & Sale of Used Assets

Ref. Nr.: 126-07011546

Overview and Technical Data:

**KRONES - Complete KRONES RBG bottling
Line Beer, Softdrinks 60.000 l**

KRONES



Baujahr: Jan. 1987



Description:

Komplette KRONES/ KHS / KETTNER - RBG Abfüllung Line Bier, Softdrinks

- Kapazität 60.000 Flaschen
- EURO Flaschengröße 0,5 l - Glas

Alles aus:

- Unpacker
- Depalettierer
- H & K Flaschenreinigungsmaschine
- KHS Flascheninspektor
- KRONES Typ VK 2V CF 144 Filler & Etikettiermaschine
- KETTNER Palletizer
- Packer
- APV Plattenwärmetauscher

Weitere Informationen folgen



Technical Data:

Technical Data:

Steuerung: CNC

Buyer Information:

Zustand: Normale Beanspruchung

Verfügbarkeit: Februar

Verkauft als:

EXW (ab Werk - Incoterm)

MwSt.: 19 %

Käuferaufgeld: 15 %

Standort: Deutschland



Images:





A

e

Assets

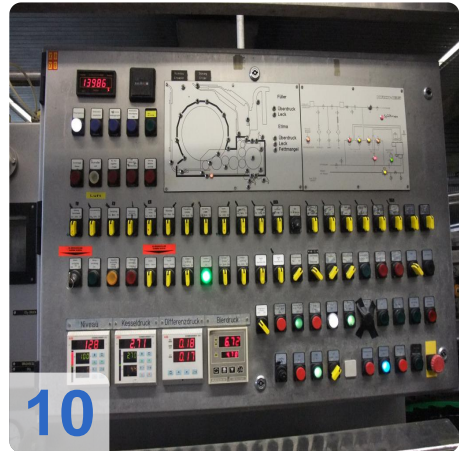
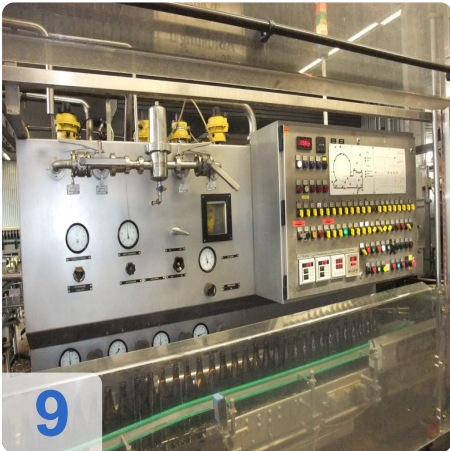



ASSET

e

Assets



12



13



14



15



16



17



As

e

ssets

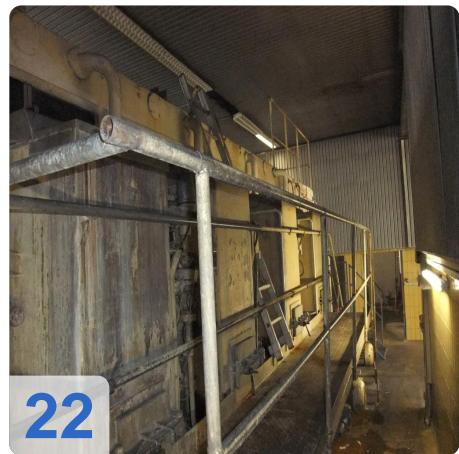



As

e

ssets

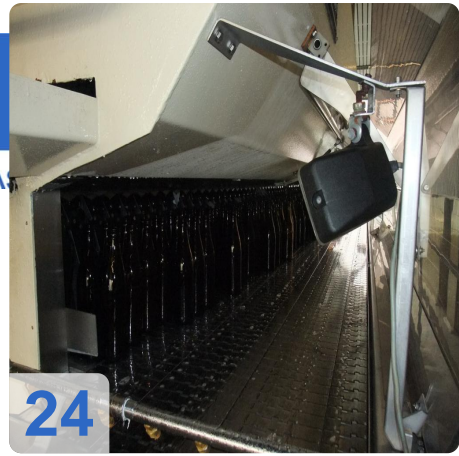

24



25



26

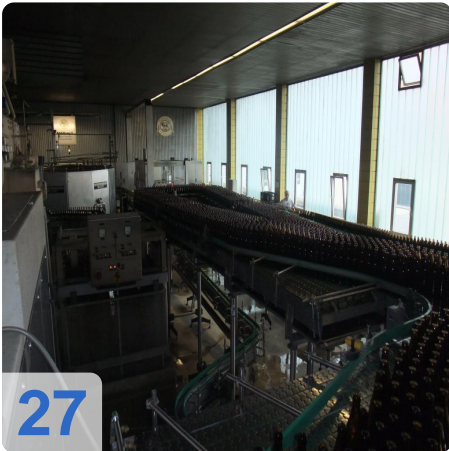

27

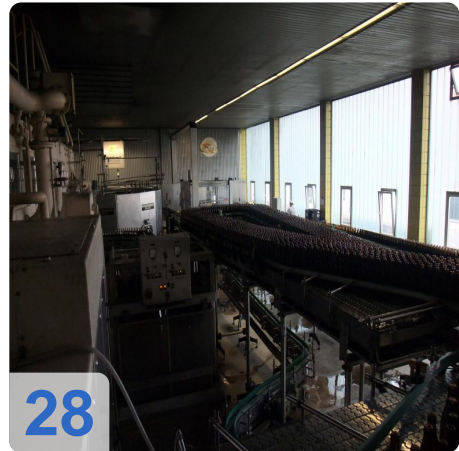

28



29



A

e

ssets

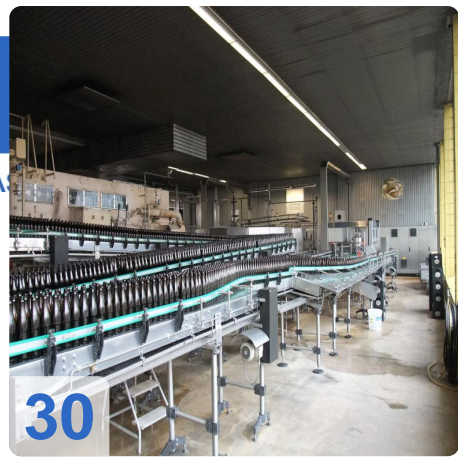



AS

e

Assets



36



37

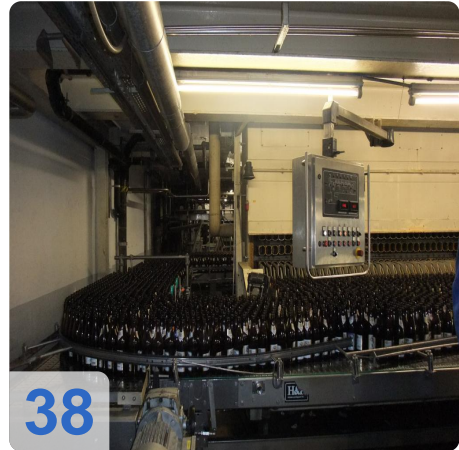

38



39

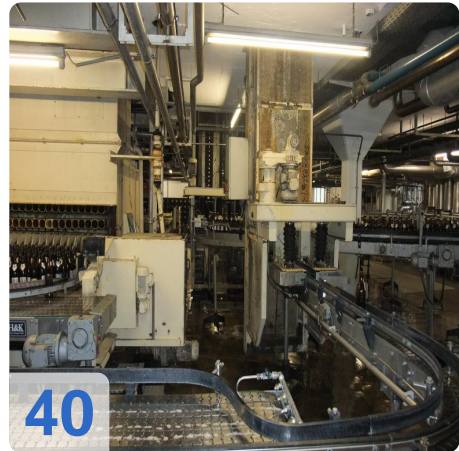

40



41



A

e

ssets

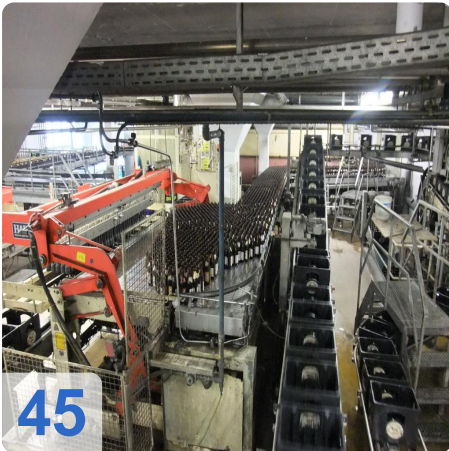
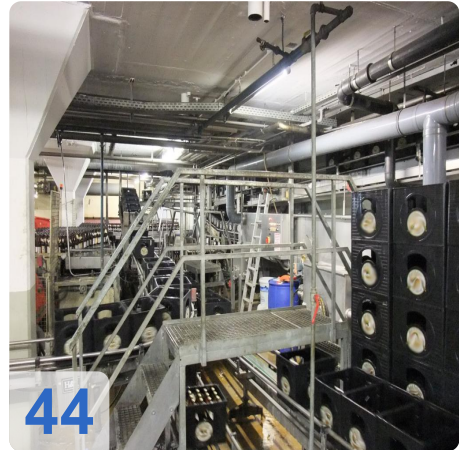
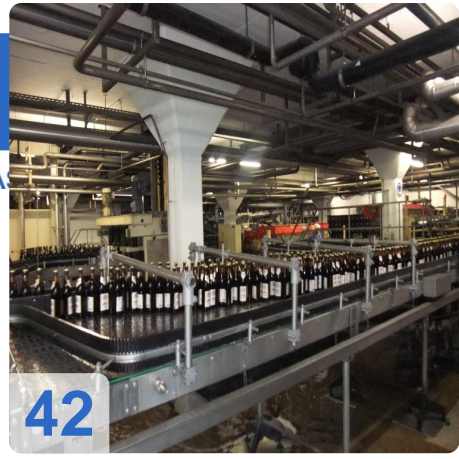



AS

e

Assets



48



49



50



51



52



53

EMPAC
Verpackungsmaschine
CH 8820 WÄRDEN
Schweiz, Schweiz
TYP 15-1500-4 SERIE-NR. 1500
BAUJAHR 1987



A

e

ssets



54

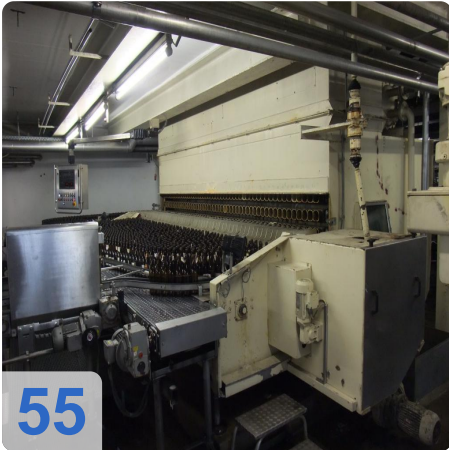

55

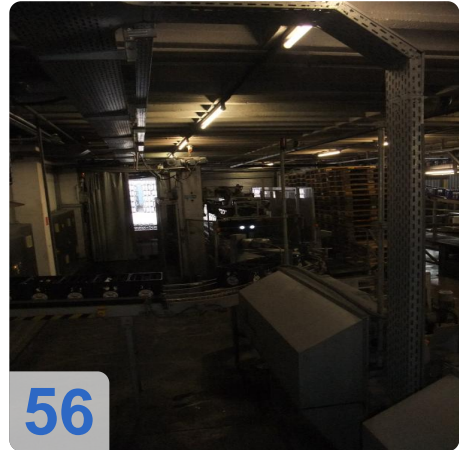

56



57

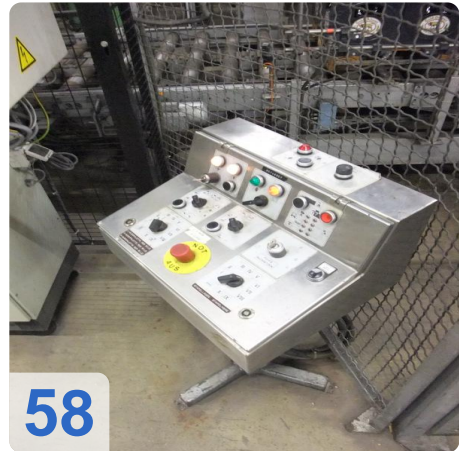

58

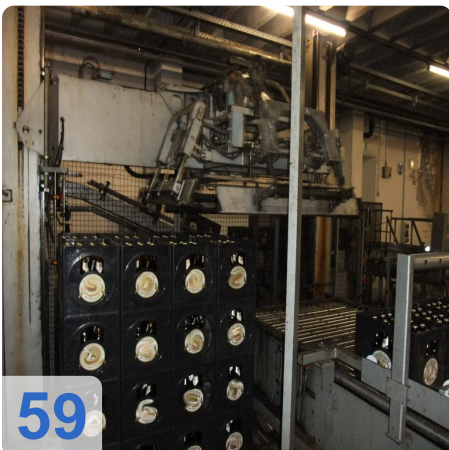

59



As

e

ssets

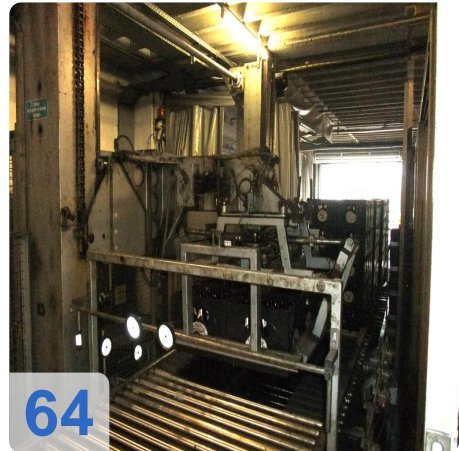
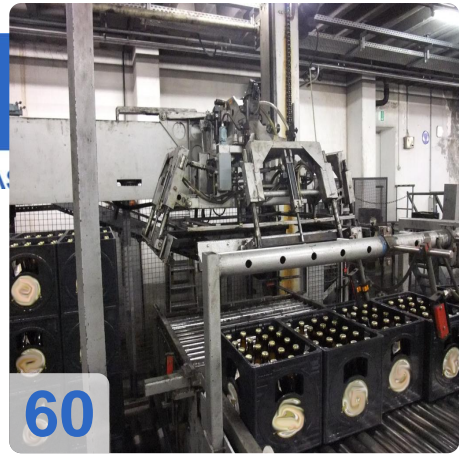



AS

e

Assets

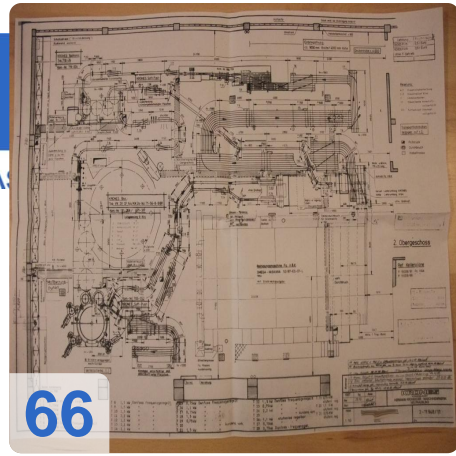

66

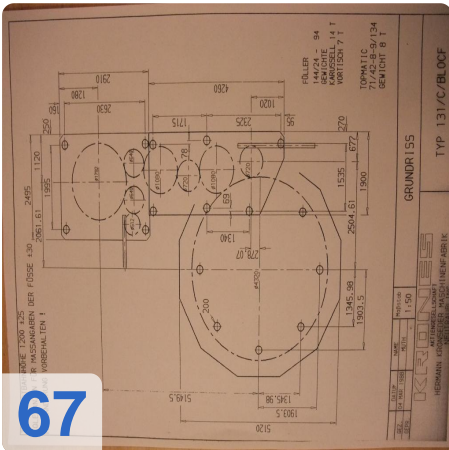

67

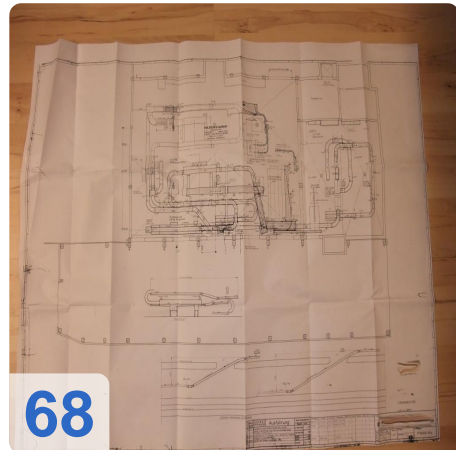

68

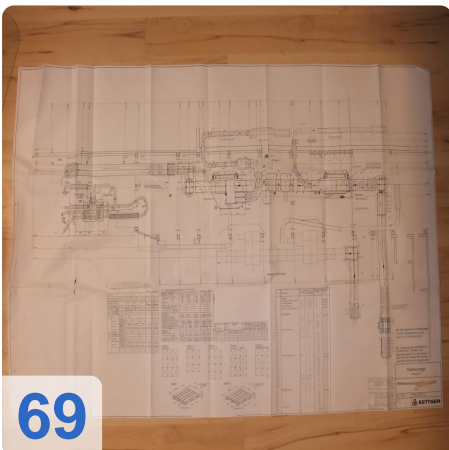

69

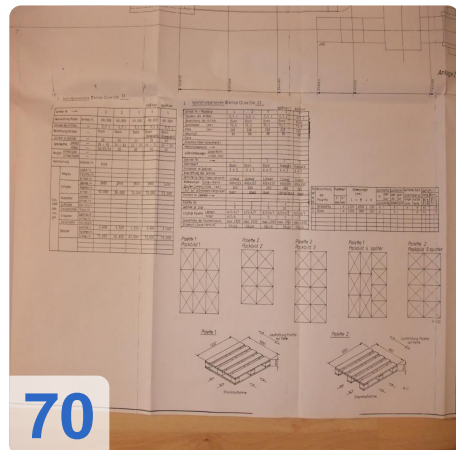

70

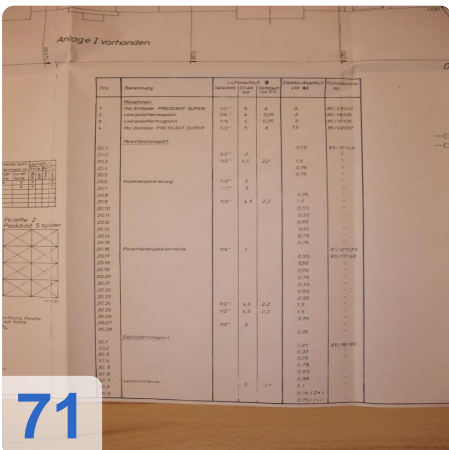

71



As

e

sssets

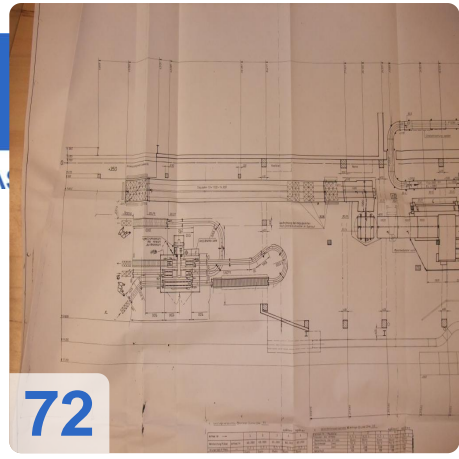

72

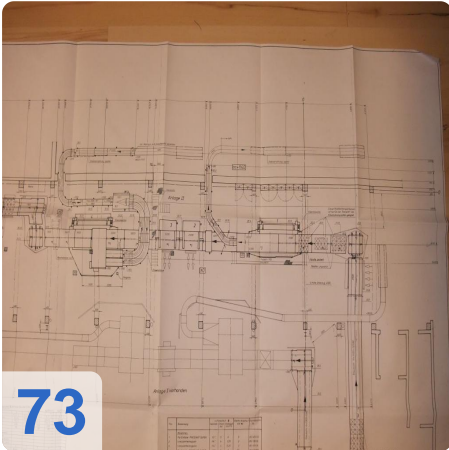

73

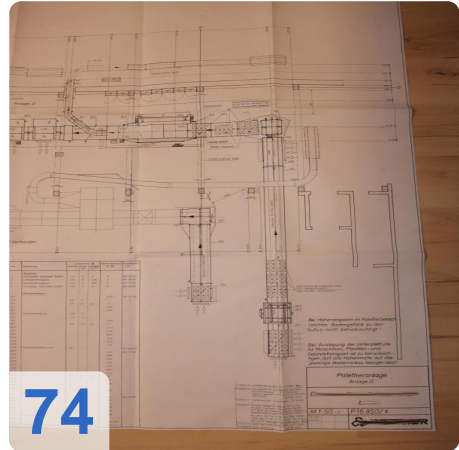

74

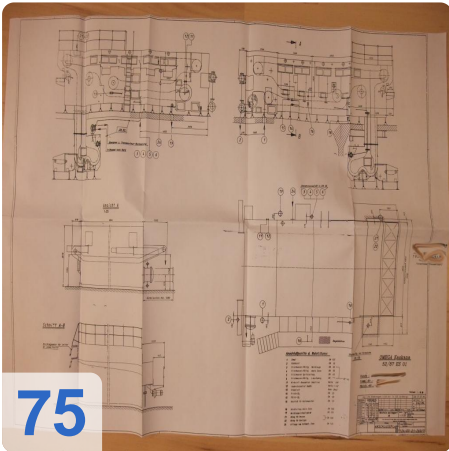

75

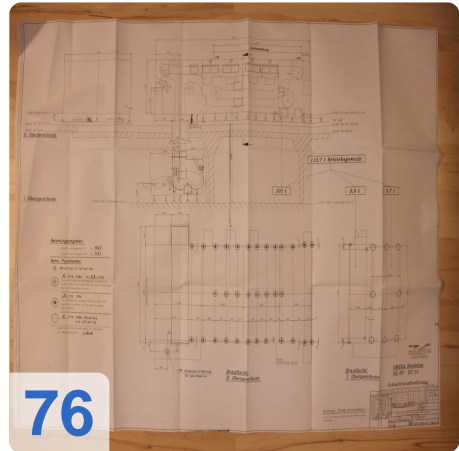

76



Asset-Trade

Assessment & Sale of Used Assets



Asset-Trade

**Bewertung & Vermarktung von
Industrieanlagen weltweit**

Am Sonnenhof 16

47800 Krefeld

Deutschland

Tel.: +49 2151 32500 33