

Image not found or type unknown



Ref. No.:

1345-07111000

Overview and Technical Data:

3x CHIRON DZ15 S Magnum high speed VMC

CHIRON

chiron



Year of Build:

Jan 2014

Description:

Used CHIRON DZ15 S Magnum high speed - vertical CNC machining centre.

3x pieces available : 1x 2013 & 2x 2014.

- CNC control : SIEMENS 840D solution line with 10,4" TFT colour screen.
- Operating hours approx. 32.500 AN / spindle 14.500 hours.

Technical data:

- Travels - Direct path measuring system in all axes:
 - X-axis: 630 mm
 - Y-axis: 400 mm
 - Z-axis: 360 mm
 - Rapid traverse speed: 75/ 75/ 75 m/min
 - NC rotary table, type ATU 200 4th axis
 - Repeat accuracy +/- 8
 - Bridge dimension 800 mm
 - Swivel radius 285 mm
 - Face plate Ø 225 mm
- Main spindle drive with 2x AC motors:
 - Speed each up to: 12,000 min⁻¹
 - 9.5 kW at 100% ED
 - 14.0 kW at 15% ED
 - Torque: max. 90 Nm
 - Spindle distance in: X-axis 320 mm
 - Coolant system / IKZ: 70 bar in 7 different pressure stages
 - Steel E335
 - Drilling capacity: 2 x Ø 36 mm
 - Thread cutting: 2 x M 24
 - Milling capacity: 2 x 150 cm³/min
- Tool changer Automatic:
 - Tool places: 2 x 32
 - Tool shank: HSK-A 63 DIN 69893
 - Tool Ø: max. 78 mm
 - Tool-Ø with free neighbouring places: max. 140 mm
 - Tool length: max. 300 mm
 - Tool weight: max. 5.0 kg
 - Tool change time: approx. 0.9 s (depending on control)
 - Chip to chip time: approx. 2.4 s (depending on control)
- Mini handwheel
- Flush gun
- Chip conveyor: 320 l
- Extinguishing system Waterfog (Minimax)
- Machine preparation for central coolant system
- Suction connection
- Tub rinsing

- Coolant package
- Hydraulic connection for 200 bar
- Operating instructions
- Renishaw probe package OMP 40-2LS
- Monitoring system as well as
 - MCIS DNC
 - Remote diagnostics and teleservice
 - V24 interface
 - Universal interface RS 232C
- Machine colour:
 - light grey according to NCS S1502-B
 - blue according to NCS S2050-R80B
 - basalt grey according to RAL 7012
- Mains connection:
 - Supply voltage machine 3x400 Volt \pm 10%
 - Voltage socket 230 Volt \pm 10%
 - 30 kVA

CHIRON 15 Series:

The 15 Series Machining Centers are best in class for speed, compact design and reliability. They have huge reserves for highly productive grinding and thanks to their modular design, for example with several spindle and table versions, they can be configured to create the perfect individual solution. Choose them for consistently fast processing and high availability with low unit costs.

Single- and double-spindle machines can be equipped with a chain-type tool changer to process complex workpieces with many tools. Alternatively, the body tool changer is currently the fastest tool change system on the market, ideal for high precision machining of countersunk holes. The FZ/DZ 15 W with load changer for loading and unloading while the machine is running are experts in large quantities, as is the TZ 15 W with four powerful spindles and workpiece changer.

CHIRON 15 Highlights

- Fast, productive machining
- Reliable performance
- Compact machine layout
- Vertical traveling column
- Mineral casting machine bed
- High rigidity and thermal stability
- Dynamic direct drives and precision guides
- High running, positioning, and long-term precision
- Robust CHIRON rotary axes
- Fully enclosed working area, stainless steel covers
- Ideal chip flow directly into the chip feeder
- Ergonomic operating and loading concept
- Easy access to all units for servicing

Technical Data:

Technical Data:

Control:

[SINUMERIK 840D](#)

Machine Hours:

32.500 hrs.

Spindle Hours:

14.500 hrs.

Spindle Speed:

12.000 rpm

Tool Holder:

[HSK-A63](#)

Tool Capacity:

32 x

Travels:

X-Axis:

630 mm

Y-Axis:

400mm

Z-Axis:

360 mm

Dimensions and Weight:

Height:

3.040 mm

Width:

3.700 mm

Length:

3.550 mm

Weight:

9.200 kg

Buyer Information:

Condition:

[Very good condition](#)

Availability:

[Immediately](#)

Sold as:

[EXW \(Ex Works - Incoterm\)](#)

VAT:

[19 %](#)

Buyers Premium:

[18 %](#)

Location:

Germany

Images:



chiron

GERMANY

52





+
CHIRON-WERKE
GmbH & Co. KG
 D-78532 TUTTLINGEN
 Kreuzstraße 75
 Type **DZ15 SM HS**
 Nr. _____
 Baujahr /
 Gewicht **2014 / 9600 kg**
MADE IN GERMANY
 + 1129701

Stromart	Kind of current	Mode d'alimentation	Alimentazione
Betriebsspannung	Working voltage	Tension de service	Tensione d'esercizio
Steuerspannung	Control voltage	Tension de commande	Tensione di controllo
max. Kurzschlussstrom	max. Short-circuit current	maxi. Courant de court-circuit	max. Corrente di cortocircuito
Leistung	Power	Puissance	Potenza
Nennstrom	Rated current	Intensité nominale	Corrente nominale
Sicherung	Fuse	Fusible	Fusibile
Stromlaufplan	Circuit diagram	Schéma électrique	Schema elettrico

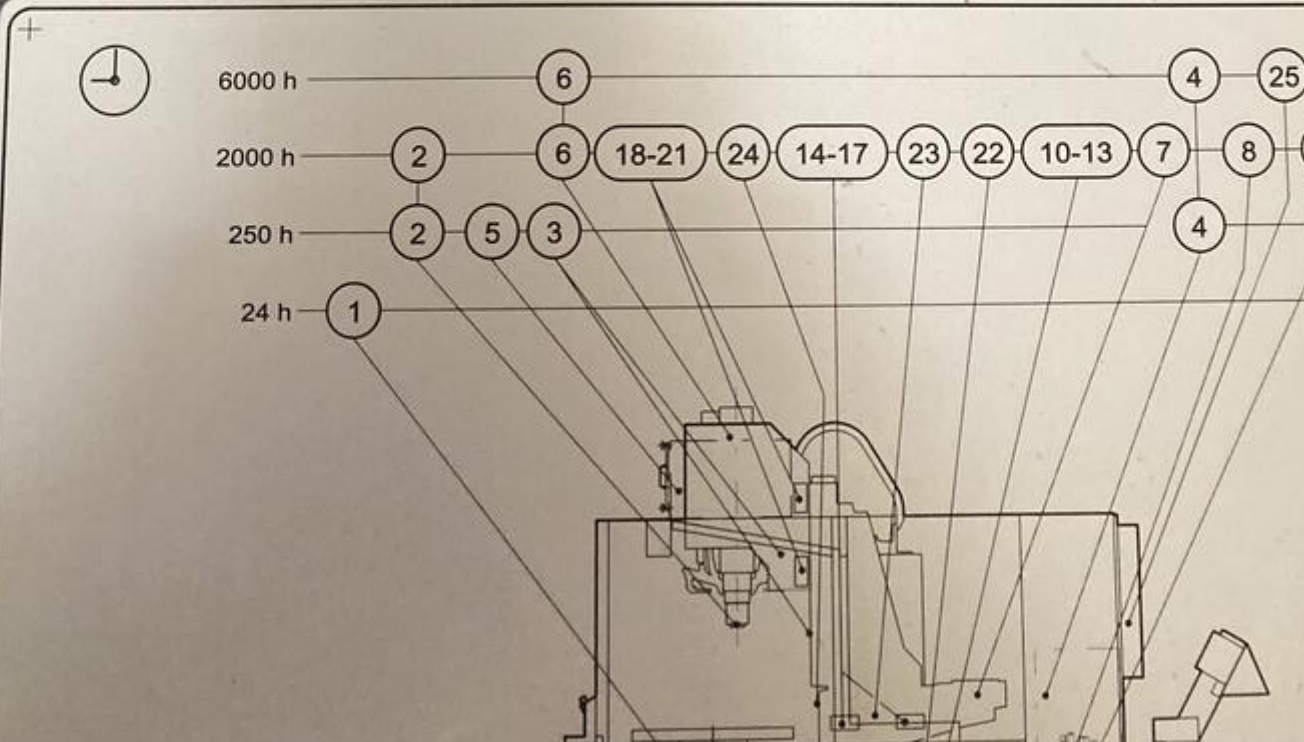



ACHTUNG
Maschine mit geschlossenem Arbeitsraum nur mit einer ausreichend dimensionierten Absauganlage betreiben.

ATTENTION
Use an mist collector of sufficient capacity if operating the machine in an enclosed working area.

ATTENTION
Ne faire fonctionner la machine avec l'espace de travail fermé qu'avec une unité d'aspiration suffisamment dimensionnée.

ATTENZIONE
Usare il centro di lavoro con zona di lavoro chiusa solo con un impianto di aspirazione ben dimensionato.

ATENCIÓN
Hacer funcionar la máquina con zona de trabajo cerrada solo con una instalación de aspiración suficientemente dimensionada.



0Q1
HAUPTSCHALTER
ACHTUNG: Bei ausgeschaltetem Hauptschalter ist nicht der gesamte Schrank spannungsfrei. Vorarbeiten ausschalten.

Die Maschine darf nur von
und autorisierten Personen
bedient werden.

Jede Person die mit der Aufstellung,
Inspektion des Fertigungszentrums
und die Sicherheitsvorschriften
beachten muss.

The machine may only
be operated by
authorized personnel.

The personnel instructed to install
the machine in the machining centre must have read
and safety regulations.

Seules des personnes
autorisées peuvent
utiliser la machine.

Toute personne s'occupant de l'installation,
l'inspection du centre d'usinage et
et les prescriptions de sécurité.

La macchina deve essere
operata
unicamente da personale
autorizzato.

Ogni persona incaricata dell'installazione,
della riparazione e dell'ispezione
deve attentamente e capire le istruzioni
di sicurezza.

La máquina solamente
debe ser operada
especialmente instruido
personal.

Cada persona, que se ocupa
de la reparación y de la inspección
y entendido la instrucciones de
seguridad.



Asset-Trade

Assessment and Sale of Used Assets world wide

Am Sonnenhof 16

47800 Krefeld

Germany

Tel.: +49 2151 32500 33

Fax.: +49 2151 65 29 22

Email: info@asset-trade.de

Web.: <https://mail.asset-trade.de/en>

Ref. No.:
1345-07111000

Overview and Technical Data:

3x CHIRON DZ15 S Magnum high speed VMC

CHIRON

chiron



Year of Build:
Jan 2014

Description:

Used CHIRON DZ15 S Magnum high speed - vertical CNC machining centre.

3x pieces available : 1x 2013 & 2x 2014.

- CNC control : SIEMENS 840D solution line with 10,4" TFT colour screen.
- Operating hours approx. 32.500 AN / spindle 14.500 hours.

Technical data:

- Travels - Direct path measuring system in all axes:
 - X-axis: 630 mm
 - Y-axis: 400 mm
 - Z-axis: 360 mm
 - Rapid traverse speed: 75/ 75/ 75 m/min
 - NC rotary table, type ATU 200 4th axis
 - Repeat accuracy +/- 8
 - Bridge dimension 800 mm
 - Swivel radius 285 mm
 - Face plate Ø 225 mm
- Main spindle drive with 2x AC motors:
 - Speed each up to: 12,000 min⁻¹
 - 9.5 kW at 100% ED
 - 14.0 kW at 15% ED
 - Torque: max. 90 Nm
 - Spindle distance in: X-axis 320 mm
 - Coolant system / IKZ: 70 bar in 7 different pressure stages
 - Steel E335
 - Drilling capacity: 2 x Ø 36 mm
 - Thread cutting: 2 x M 24
 - Milling capacity: 2 x 150 cm³/min
- Tool changer Automatic:
 - Tool places: 2 x 32
 - Tool shank: HSK-A 63 DIN 69893
 - Tool Ø: max. 78 mm
 - Tool-Ø with free neighbouring places: max. 140 mm
 - Tool length: max. 300 mm
 - Tool weight: max. 5.0 kg
 - Tool change time: approx. 0.9 s (depending on control)
 - Chip to chip time: approx. 2.4 s (depending on control)
- Mini handwheel
- Flush gun
- Chip conveyor: 320 l
- Extinguishing system Waterfog (Minimax)
- Machine preparation for central coolant system
- Suction connection
- Tub rinsing
- Coolant package
- Hydraulic connection for 200 bar
- Operating instructions
- Renishaw probe package OMP 40-2LS
- Monitoring system as well as
 - MCIS DNC
 - Remote diagnostics and teleservice
 - V24 interface
 - Universal interface RS 232C
- Machine colour:

- light grey according to NCS S1502-B
 - blue according to NCS S2050-R80B
 - basalt grey according to RAL 7012
 - Mains connection:
 - Supply voltage machine 3x400 Volt \pm 10%
 - Voltage socket 230 Volt \pm 10%
 - 30 kVA
-

CHIRON 15 Series:

The 15 Series Machining Centers are best in class for speed, compact design and reliability. They have huge reserves for highly productive grinding and thanks to their modular design, for example with several spindle and table versions, they can be configured to create the perfect individual solution. Choose them for consistently fast processing and high availability with low unit costs.

Single- and double-spindle machines can be equipped with a chain-type tool changer to process complex workpieces with many tools. Alternatively, the body tool changer is currently the fastest tool change system on the market, ideal for high precision machining of countersunk holes. The FZ/DZ 15 W with load changer for loading and unloading while the machine is running are experts in large quantities, as is the TZ 15 W with four powerful spindles and workpiece changer.

CHIRON 15 Highlights

- Fast, productive machining
- Reliable performance
- Compact machine layout
- Vertical traveling column
- Mineral casting machine bed
- High rigidity and thermal stability
- Dynamic direct drives and precision guides
- High running, positioning, and long-term precision
- Robust CHIRON rotary axes
- Fully enclosed working area, stainless steel covers
- Ideal chip flow directly into the chip feeder
- Ergonomic operating and loading concept
- Easy access to all units for servicing

Technical Data:

Technical Data:

Control:

[SINUMERIK 840D](#)

Machine Hours:

32.500 hrs.

Spindle Hours:

14.500 hrs.

Spindle Speed:

12.000 rpm

Tool Holder:

HSK-A63

Tool Capacity:

32 x

Travels:

X-Axis:

630 mm

Y-Axis:

400mm

Z-Axis:

360 mm

Dimensions and Weight:

Height:

3.040 mm

Width:

3.700 mm

Length:

3.550 mm

Weight:

9.200 kg

Buyer Information:

Condition:

Very good condition

Availability:

Immediately

Sold as:

EXW (Ex Works - Incoterm)

VAT:

19 %

Buyers Premium:

18 %

Location:

Germany

Images:



chiron

GERMANY

52





+
CHIRON-WERKE
GmbH & Co. KG
 D-78532 TUTTLINGEN
 Kreuzstraße 75
 Type **DZ15 SM HS**
 Nr. _____
 Baujahr /
 Gewicht **2014 / 9600 kg**
MADE IN GERMANY
 + 1129701

Stromart	Kind of current	Mode d'alimentation	Alimentazione
Betriebsspannung	Working voltage	Tension de service	Tensione d'esercizio
Steuerspannung	Control voltage	Tension de commande	Tensione di controllo
max. Kurzschlussstrom	max. Short-circuit current	maxi. Courant de court-circuit	max. Corrente di cortocircuito
Leistung	Power	Puissance	Potenza
Nennstrom	Rated current	Intensité nominale	Corrente nominale
Sicherung	Fuse	Fusible	Fusibile
Stromlaufplan	Circuit diagram	Schéma électrique	Schema elettrico

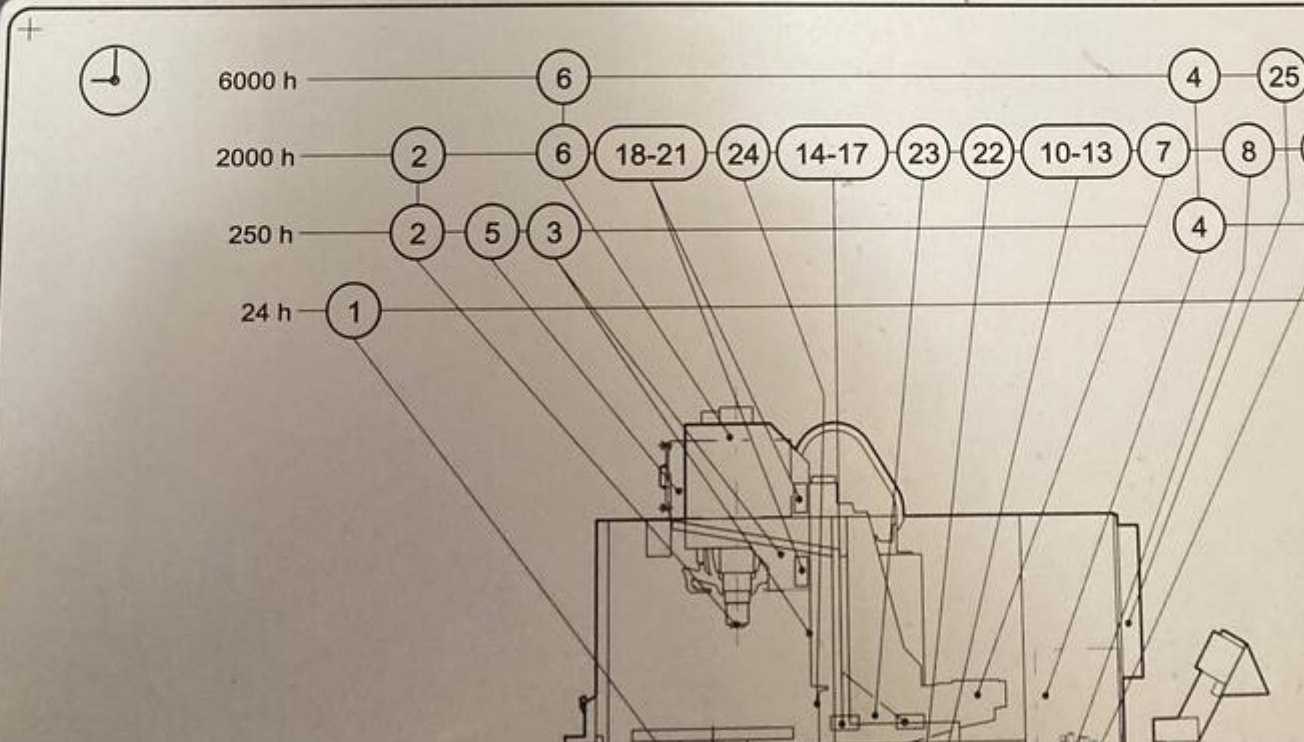



ACHTUNG
Maschine mit geschlossenem Arbeitsraum nur mit einer ausreichend dimensionierten Absauganlage betreiben.

ATTENTION
Use an mist collector of sufficient capacity if operating the machine in an enclosed working area.

ATTENTION
Ne faire fonctionner la machine avec l'espace de travail fermé qu'avec une unité d'aspiration suffisamment dimensionnée.

ATTENZIONE
Usare il centro di lavoro con zona di lavoro chiusa solo con un impianto di aspirazione ben dimensionato.

ATENCIÓN
Hacer funcionar la máquina con zona de trabajo cerrada solo con una instalación de aspiración suficientemente dimensionada.



0Q1
HAUPTSCHALTER
ACHTUNG: Bei ausgeschaltetem Hauptschalter ist nicht der gesamte Schrank spannungsfrei. Vorarbeiten ausschalten.

Die Maschine darf nur von
und autorisierten Personen

Jede Person die mit der Aufstellung,
Inspektion des Fertigungszentrums
und die Sicherheitsvorschriften

The machine may only be
authorized personnel.

The personnel instructed to install
machining centre must have read
and safety regulations.

Seules des personnes
utiliser la machine.

Toute personne s'occupant de l'
inspection du centre d'usinage
et les prescriptions de sécurité.

La macchina deve essere
unicamente da personale
ed autorizzato.

Ogni persona incaricata dell'
della riparazione e dell'ispezione
attentamente e capire le istruzioni.

La máquina solamente
especialmente instruido.

Cada persona, que se ocupa
reparación y de la inspección
y entendido la instrucciones



Asset-Trade

Assessment and Sale of Used Assets world wide

Am Sonnenhof 16

47800 Krefeld

Germany

Tel.: +49 2151 32500 33

Fax.: +49 2151 65 29 22

Email: info@asset-trade.de

Web.: <https://mail.asset-trade.de/en>

Generated on 22.04.2026

© Copyright 2026 - [Asset-Trade](#)

Page